

The **ADVANCED WATER VAPOR PERMEABILITY TESTER**

PMI - PVTA - 100 A

The PMI Advanced Water Vapor Permeability Tester is able to measure water vapor transmission rate through plastic film, metals, foils, laminated film, paper sheets, other barrier sheet materials and packages. The measurements conform to ISO 15106-3.



Not just products...*solutions!*

Application

The PMI AdWater Vapor Permeability Tester is capable of measuring water vapor transmission through porous media such as textiles, leathers, man made materials, membranes, nonwovens, and fabrics used in numerous high technology components and consumer products manufactured by a variety of industries. The instrument has the unique ability to measure vapor transmission rate over a wide range of humidity, temperature, and pressure under gradients of humidity, temperature, and pressure encountered in application environments.

Principle

Two independent gas streams are maintained on the two sides of a sample at the desired temperature. Humidity and gas flow rates are measured. The transmission rate through the sample is computed using mass balance.

$$\frac{dn}{dt} + [(p_{e,i} \Phi_i / P_i) M_i] = [(p_{e,o} \Phi_o / P_o) M_o]$$

Where

n = moles Φ = humidity M = flow rate
 t = time p = equilibrium vapor pressure
 i = inlet o = outlet P = total pressure
 $\frac{dn}{dt}$

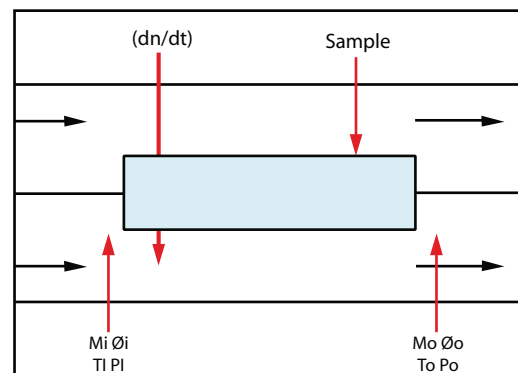

Figure 2

Basic principle of the Water Vapor Permeability Tester

Instrument

The sample is enclosed in a sample chamber. A part of the gas flowing through each independent stream is allowed to go through bubblers while the other part bypasses the bubblers and mixes with the gas passing through the bubblers. For maintaining constant humidity in the inlet gas stream, the flow rate in each part of the gas stream is controlled. The gas pressure is controlled by the valve at the end of each gas flow line. The valves automatically control and maintain either zero differential pressure or a finite definite pressure difference. Absolute pressure remains close to the standard pressure. The inlet and outlet flow rates and humidity are measured. The water vapor transmission rate through the sample is computed using the following relation.

$$\frac{dn}{dt} = [(p_e/P) \Phi_o - (p_e/P) \Phi_i] M_o / [1 - (p_e/P) \Phi_i]$$

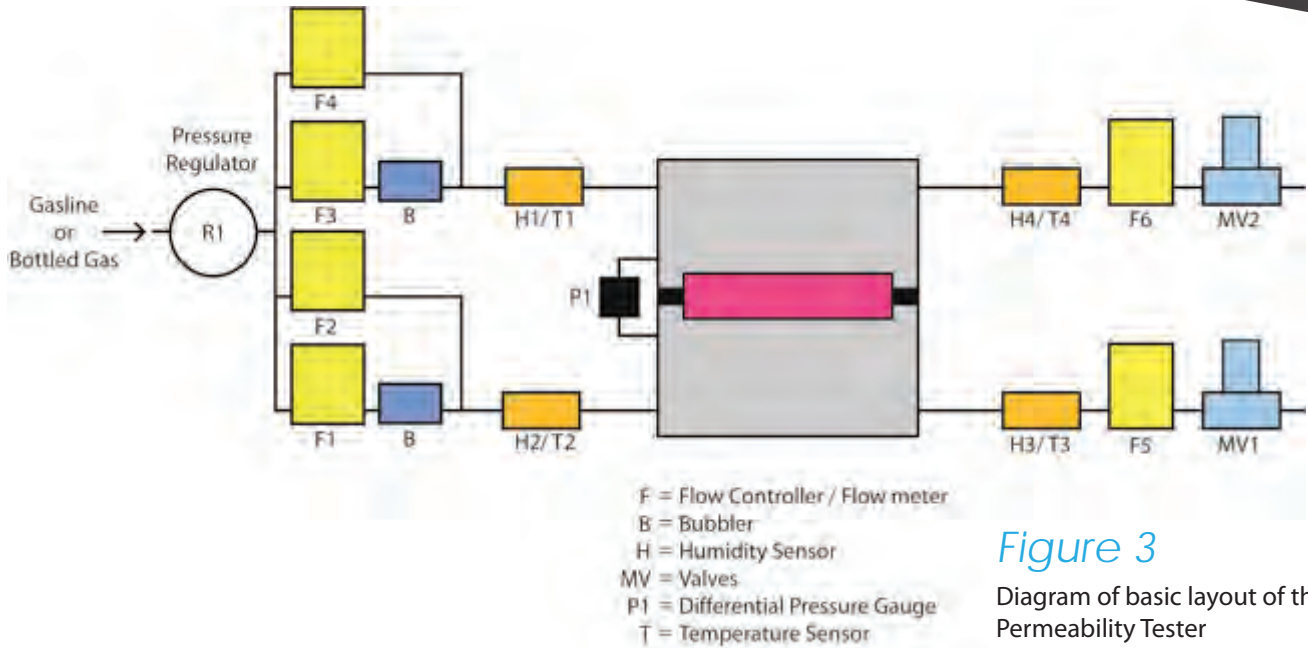

Figure 3

Diagram of basic layout of the Water Vapor Permeability Tester

Features

- Humidity on any side can be maintained between 5% and 95%
- Any desired pressure gradient can be maintained
- Any desired test temperature can be achieved
- Simultaneous pressure and humidity gradients can be maintained
- Flat samples in a wide range of sizes can be accommodated
- Completely automated

Specifications*

Sample Size:

minimum 100 mm x 100 mm for film

Humidity (ϕ) measurement:

Range: 5 - 95% Accuracy: $\pm 2\%$

Humidity (ϕ) control:

35% - 90% RH with precision of ± 3 RH

Temperature:

Range: 15°C -50 °C Control: $\pm 2\%$ Accuracy: ± 3 °C

Differential pressure transducers:

Range: 4 torr (2 mm Hg) Accuracy: 0.015%

Mass Flow Transducers:

Accuracy: 1%

Mass Flow Controller:

Range: 2000 cc/min Accuracy: 1%

Resolution:

0.0001 g/m² day

* Other specifications for this machine are available. Specifications are subject to change without notice.

Sales & Services

Our sales team is dedicated to helping our customers find which machine is right for their situation. We also offer custom machines for customers with unique needs. To find out what we can do for you, contact us.

We are committed to customer support including specific service products, short response times & customer specific solutions. To quickly & flexibly meet our customer's requirement, we offer a comprehensive range of services.



Customize your machine today!



20 Dutch Mill Rd, Ithaca, NY 14850, USA
Toll Free (US & Canada): 1-800-TALK-PMI (1-800-825-5764)
Phone: 607-257-5544 Fax: 607-257-5639

Email: info@pmiapp.com

www.pmiapp.com

The most advanced, accurate, easy to use
and reproducible porometers in the world.



20 Dutch Mill Rd, Ithaca, NY 14850, USA
Toll Free (US & Canada): 1-800-TALK-PMI (1-800-825-5764)
Phone: 607-257-5544 Fax: 607-257-5639

Email: info@pmiapp.com

www.pmiapp.com